

# DATA SHEET

## **NE83Q93**

Enhanced coaxial Ethernet transceiver

Product specification

1995 May 01

IC19 Data Handbook

# Enhanced coaxial Ethernet transceiver

# NE83Q93

## DESCRIPTION

The NE83Q93 is a low power coaxial transceiver interface (CTI) for Ethernet (10base5) and Thin Ethernet (10base2) local area networks. The CTI is connected between the coaxial cable and the Data Terminal Equipment (DTE) and consists of a receiver, transmitter, receive-mode collision detector, heartbeat generator and jabber timer (see Block Diagram). The transmitter output connects directly to a doubly terminated 50Ω cable, while the receiver output, collision detector output and transmitter input are connected to the DTE through isolation transformers. Isolation between the CTI and the DTE is an IEEE 802.3 requirement that can be met on signal lines by using a set of pulse transformers. Power isolation for the CTI is achieved using DC-to-DC conversion through a power transformer (see Figure 3, Connection Diagram).

The part is functionally the same as the NE83Q92, but with additional features such as a transmit enable input, a carrier detect output and five status LED driver outputs.

The NE83Q93 is manufactured on an advanced BiCMOS process and is available in an SOL package making it ideally suited to lap-top personal computers or systems where low power consumption, limited board space and jumperless design is required. Refer to selection flow chart for optimal application.

## PIN CONFIGURATION

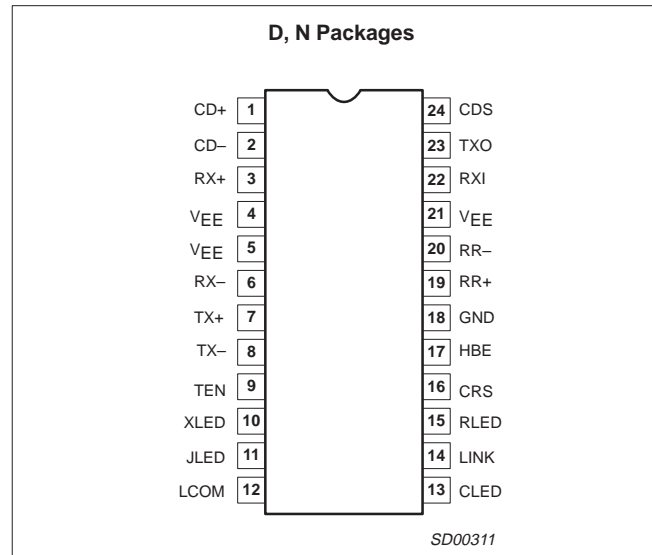

Figure 1. Pin Configurations

## FEATURES

- Fully compliant with Ethernet II, IEEE 802.3 10BASE-5 and 10BASE-2, and ISO 8802/3 interface specifications
- Functionally compatible with industry standard 8392 applications
- Optimal implementation can use 1 Watt DC-DC converter and reduces external parts count
- High efficiency AUI drivers minimize current consumption under idle conditions by automatically powering-down
- Automatically disables AUI drivers when disconnecting coax cable, allowing hard-wiring of AUI connector and local/integrated CTI connection

- Smart squelch on data inputs eliminates false activations
- Transmit enable input and carrier sense output for repeater applications
- Five LED status drivers for transmit, receive, collision, jabber and link fail indication
- Advanced BiCMOS process for extremely low power operation
- Available in 24-pin DIP and 24-pin SOL packages
- Full ESD protection
- Power-on reset prevents glitches on coaxial cable

## ORDERING INFORMATION

| DESCRIPTION                                      | TEMPERATURE RANGE | ORDER CODE | DWG #    |
|--|-------------------|------------|----------|
| 24-Pin Plastic Dual In-Line Package (DIP)        | 0 to +70°C        | NE83Q93N   | SOT222-1 |
| 24-Pin Plastic Small Outline Large (SOL) Package | 0 to +70°C        | NE83Q93D   | SOT137-1 |

## Enhanced coaxial Ethernet transceiver

NE83Q93

## PIN DESCRIPTIONS

| PIN NO.<br>D, N PKG | SYMBOL     | DESCRIPTION  |
|---------------------|------------|--|
| 1<br>2              | CD+<br>CD- | <b>Collision Outputs.</b> Balanced differential line driver outputs which send a 10MHz signal to the DTE in the event of a collision, jabber interrupt or heartbeat test. External pull-down resistors are optional.   |
| 3<br>6              | RX+<br>RX- | <b>Receiver Outputs.</b> Balanced differential line driver outputs which send the received signal to the DTE. External pull-down resistors are optional.   |
| 7<br>8              | TX+<br>TX- | <b>Transmitter Inputs.</b> Balanced differential line receiver inputs which accept the transmission signal from the DTE and apply it to the coaxial cable at TXO, if it meets Tx squelch threshold.  |
| 9                   | TEN        | <b>Transmit Enable.</b> A CMOS compatible input requiring an input voltage range of $V_{EE}$ to $V_{EE} + 5V$ . The transmitter and loopback functions are disabled when TEN is LOW and enabled when TEN is HIGH or left floating. TEN is normally driven through an opto-coupler. |
| 10                  | XLED       | <b>Transmit Indicator.</b> Indicates a packet is being transmitted onto the coaxial cable.   |
| 11                  | JLED       | <b>Jabber Indicator.</b> Indicates that the jabber timer has timed out and the coaxial driver is disabled.   |
| 12                  | LCOM       | <b>LED Common.</b> The anodes of all status indicator LEDs are connected to this pin. It's voltage is $V_{EE} + 5V$ .  |
| 13                  | CLED       | <b>Collision Indicator.</b> Indicates that a collision has been detected.  |
| 14                  | LINK       | <b>Link Indicator.</b> Indicates that a connection is present to the coaxial cable network.  |
| 15                  | RLED       | <b>Receive Indicator.</b> Indicates that a packet is being received from the coaxial cable.  |
| 16                  | CRS        | <b>Carrier Sense.</b> A real time output that indicates the presence of a carrier on the coaxial cable. CRS is normally used to drive an opto-coupler.   |
| 17                  | HBE        | <b>Heartbeat Enable.</b> The heartbeat function is disabled when this pin is connected to $V_{EE}$ and enabled when connected to GND or left floating.   |
| 11<br>12            | RR+<br>RR- | <b>External Resistor.</b> A 1k $\Omega$ (1%) resistor connected between these pins establishes the signaling current at TXO.   |
| 22                  | RXI        | <b>Receiver Input.</b> This pin is connected directly to the coaxial cable. Received signals are equalized, amplified, and sent to the DTE through the $RX_{\pm}$ pins, if it meets Rx squelch threshold.  |
| 23                  | TXO        | <b>Transmitter Output.</b> This pin is connected directly (Thin Ethernet) or through an external isolating diode (Ethernet) to the coaxial cable.  |
| 24                  | CDS        | <b>Collision Detect Sense.</b> Ground sense connection for the collision detection circuitry. This pin should be connected directly to the coaxial cable shield for standard Ethernet operation.   |
| 18                  | GND        | <b>Positive Supply Pin.</b>  |
| 4<br>5<br>21        | $V_{EE}$   | <b>Negative supply pins.</b>   |

## NOTE:

- The IEEE 802.3 name for CD is CI; for RX is DI; for TX is DO.

# Enhanced coaxial Ethernet transceiver

# NE83Q93

## BLOCK DIAGRAM

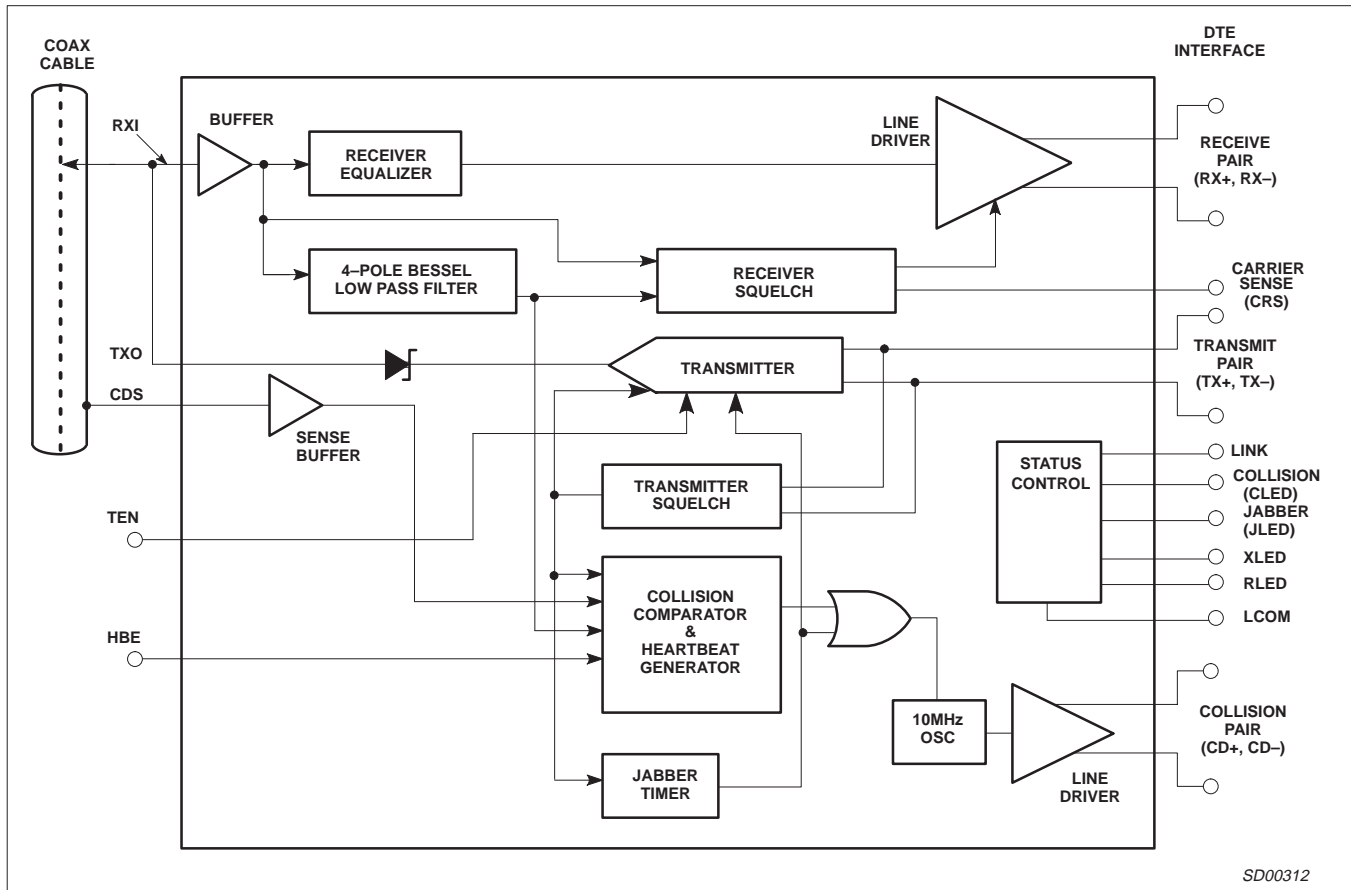

Figure 2. Block Diagram

## ABSOLUTE MAXIMUM RATINGS

| SYMBOL        | PARAMETER   | RATING      | UNIT |
|---------------|---|-------------|------|
| $V_{EE}$      | Supply voltage <sup>1</sup>                       | -12         | V    |
| $V_{IN}$      | Voltage at any input <sup>1</sup>                 | 0 to -12    | V    |
| $T_{STG}$     | Storage temperature range                         | -65 to +150 | °C   |
| $T_{SOLD}$    | Lead soldering temperature (10sec.)               | +300        | °C   |
| $T_J$         | Recommended max junction temperature <sup>2</sup> | +150        | °C   |
| $\theta_{JA}$ | Thermal impedance (N and A packages)              | 60          | °C/W |

### NOTE:

- 100% measured in production.
- The junction temperature is calculated from the following expression:  

$$T_J = T_A + \theta_{JA} [(V_{EE} \times 0.015 \times n_{IDL}) + (V_{EE} \times 0.027 \times n_{RX}) + (V_{EE} \times 0.075 \times n_{TX})]$$
 where  
 $T_A$  = Ambient temperature in °C.  
 $\theta_{JA}$  = Thermal resistance of package.  
 $V_{EE}$  = Normal operating supply voltage in volts.  
 $n_{IDL}$  = Percentage of duty cycle idle  
 $n_{RX}$  = Percentage of duty cycle receiving  
 $n_{TX}$  = Percentage of duty cycle transmitting

## Enhanced coaxial Ethernet transceiver

NE83Q93

**ELECTRICAL CHARACTERISTICS** $V_{EE} = -9V \pm 6\%$ ;  $T_A = 0^\circ C$  to  $+70^\circ C$  unless otherwise specified<sup>1,2</sup>. No external isolation.

| SYMBOL                           | PARAMETER  | TEST CONDITIONS                                       | LIMITS         |              |                | UNIT       |
|----------------------------------|--|---|----------------|--------------|----------------|------------|
|                                  |  |   | MIN            | TYP          | MAX            |            |
| $V_{UVL}$                        | Under voltage lockout. Transceiver disabled for $ V_{EE}  <  V_{UVL} $                 |   |                | -7.5         |                | V          |
| $I_{EE}$                         | Supply current idle  |   |                | -15          | -20            | mA         |
|                                  | Supply current transmitting (without collision)  | Without external pull-down resistors and no LED loads |                | -80          | -90            | mA         |
| $I_{RXI}$                        | Receive input bias current   | $V_{RXI} = 0V$  | -2             |              | +25            | $\mu A$    |
| $I_{CDS}$                        | Cable sense input bias current   | $V_{CDS} = 0V$  |                | +1           | +3             | $\mu A$    |
| $V_{IH}$                         | HBE input HIGH voltage   |   | $V_{EE} + 2.4$ |              |                | V          |
| $V_{IL}$                         | HBE input LOW voltage  |   |                |              | $V_{EE} + 1.6$ | V          |
| $I_{IH}$                         | HBE input HIGH current   | $V_{HBE} = 0V$  |                |              | +10            | $\mu A$    |
| $I_{IL}$                         | HBE input LOW current  | $V_{HBE} = V_{EE}$                                    | -30            |              |                | $\mu A$    |
| $V_{TENH}$                       | Input HIGH voltage at TEN  |   |                | $V_{EE} + 2$ |                | V          |
| $V_{TENL}$                       | Input LOW voltage at TEN   |   |                | $V_{EE} + 1$ |                | V          |
| $I_{TENL}$                       | Input LOW current at TEN   |   |                | -50          | -100           | $\mu A$    |
| $I_{TDC}$                        | Transmit output DC current level <sup>3</sup>  |   | -37            |              | -45            | mA         |
| $I_{TAC}$                        | Transmit output AC current level <sup>3</sup>  |   | $\pm 28$       |              | $\pm I_{TDC}$  | mA         |
| $I_{TX10}$                       | Transmit current   | $V_{TXO} = -10V$                                      | -250           |              | +250           | $\mu A$    |
| $V_{TCOM}$                       | Transmitter output voltage compliance <sup>4</sup>                                     |   |                |              | -3.7           | V          |
| $V_{CD}$                         | Collision threshold <sup>5</sup>   | Measured by applying DC voltage at RXI (CDS = 0V)     | -1450          | -1530        | -1580          | mV         |
| $V_{DIS}$                        | AUI disable voltage at RXI   | Measured as DC voltage at RXI                         |                | -3.5         |                | V          |
| $V_{OD}$                         | Differential output voltage – non idle at $RX_{\pm}$ and $CD_{\pm}$ <sup>6</sup>       |   | $\pm 600$      |              | $\pm 1100$     | mV         |
| $V_{OB}$                         | Differential output voltage imbalance – idle at $RX_{\pm}$ and $CD_{\pm}$ <sup>7</sup> |   |                |              | $\pm 40$       | mV         |
| $V_{OC}$                         | Output common mode voltage at $RX_{\pm}$ and $CD_{\pm}$                                | $RXI = 0V$  | -4.0           | -5.5         | -7.0           | V          |
| $V_{RS}$                         | Receiver squelch threshold   | $V_{RXI}$ average DC (CDS = 0V)                       | -150           | -250         | -350           | mV         |
| $V_{TS}$                         | Transmitter squelch threshold  | $(V_{TX+} - V_{TX-})$ peak                            | -175           | -225         | -275           | mV         |
| $R_{RXI}$                        | Shunt resistance at RXI non-transmitting   |   | 100            |              |                | k $\Omega$ |
| $C_{RXI}$                        | Input capacitance at RXI <sup>8</sup>  |   |                | 1            | 2              | pF         |
| $R_{TXO}$                        | Shunt resistance at TXO transmitting   |   | 7.5            | 10           |                | k $\Omega$ |
| $R_{AUIZ}$                       | Differential impedance at $RX_{\pm}$ and $CD_{\pm}$ with no coaxial cable connected    |   |                | 6            |                | k $\Omega$ |
| $R_{TX}$                         | Differential impedance at $TX_{\pm}$   |   |                | 20           |                | k $\Omega$ |
| <b>LED driver and CRS output</b> |  |   |                |              |                |            |
| $V_{OL}$                         | Output LOW voltage   | $I_{OUT} = 8mA$                                       |                |              | $V_{EE} + 1.4$ | V          |
| $I_{OL}$                         | Output leakage current inactive  | $V_{EE} < V_{OUT} < V_{EE} + 5$                       |                |              | 10             | $\mu A$    |

**NOTES:**

- Currents flowing into device pins are positive. All voltages are referenced to ground unless otherwise specified. For ease of interpretation, the parameter limit that appears in the MAX column is the largest value of the parameter, irrespective of sign. Similarly, the value in the MIN column is the smallest value of the parameter, irrespective of sign.
- All typicals are for  $V_{EE} = -9V$  and  $T_A = 27^\circ C$ .
- $I_{TDC}$  is measured as  $(V_{MAX} + V_{MIN}) / (2 \times 25)$  where  $V_{MAX}$  and  $V_{MIN}$  are the max and min voltages at TXO with a 25 $\Omega$  load between TXO and GND.  $I_{TAC}$  is measured as  $(V_{MAX} - V_{MIN}) / (2 \times 25)$ .
- The TXO pin shall continue to sink at least  $I_{TDC}$  min when the idle (no signal) voltage on this pin is -3.7V.
- Collision threshold for an AC signal is within 5% of  $V_{CD}$ .
- Measured on secondary side of isolation transformer (see Connection Diagram, Figure 3). The transformer has a 1:1 turns ratio with an inductance between 30 and 100 $\mu H$  at 5MHz.
- Measured as the voltage difference between the RX pins or the CD pins with the transformer removed.
- Not 100% tested in production.

## Enhanced coaxial Ethernet transceiver

NE83Q93

**TIMING CHARACTERISTICS**

$V_{EE} = -9V \pm 6\%$ ;  $T_A = 0$  to  $70^\circ\text{C}$ , unless otherwise specified<sup>1</sup>. No external isolation diode on TXO.

| SYMBOL        | PARAMETER  | TEST CONDITIONS        | LIMITS |         |               | UNIT          |
|---------------|--|------------------------|--------|---------|---------------|---------------|
|               |  |                        | MIN    | TYP     | MAX           |               |
| $t_{RON}$     | Receiver start up delay RXI to RX $\pm$ (Figure 6)<br>First received bit on RX $\pm$                     | $V_{RXI} = -2V$ peak   |        | 3       | 5             | bits          |
|               | First validly timed bit on RX $\pm$  |                        |        |         | $t_{RON} + 2$ | bits          |
| $t_{RD}$      | Receiver prop. delay RXI to RX $\pm$   | $V_{RXI} = -2V$ peak   |        | 20      | 50            | ns            |
| $t_{RR}$      | Differential output rise time on RX $\pm$ and CD $\pm$ <sup>2,3</sup>                                    |                        |        | 5       | 7             | ns            |
| $t_{RF}$      | Differential output fall time on RX $\pm$ and C $\pm$ <sup>2,3</sup>                                     |                        |        | 5       | 7             | ns            |
| $t_{OS}$      | Differential output settling time on RX $\pm$ and CD $\pm$<br>to $V_{OB} = 40\text{mV}^2$ (see Figure 7) |                        |        | 1       |               | $\mu\text{s}$ |
| $t_{RJ}$      | Receiver and cable total jitter  |                        |        | $\pm 2$ | $\pm 6$       | ns            |
| $t_{RHI}$     | Receiver high to idle time   | Measured to +210mV     | 200    |         | 850           | ns            |
| $t_{RM}$      | Rise and fall time matching on RX $\pm$ and CD $\pm$   | $t_{RF} - t_{RR}$      |        | 0.1     | $\pm 2$       | ns            |
| $t_{TST}$     | Transmitter start-up delay TX $\pm$ to TXO (Fig. 8)<br>First transmitted bit on TXO                      | $V_{TX\pm} = -1V$ peak |        | 1       | 2             | bits          |
|               | First validly timed bit  |                        |        |         | $t_{TST} + 2$ | bits          |
| $t_{TD}$      | Transmitter prop delay TX $\pm$ to TXO<br>(see Figure 8)   | $V_{TX\pm} = 1V$ peak  | 5      | 20      | 50            | ns            |
| $t_{TR}$      | Transmitter rise time 10% to 90% (see Figure 8)  |                        | 20     | 25      | 30            | ns            |
| $t_{TF}$      | Transmitter fall time 10% to 90% (see Figure 8)  |                        | 20     | 25      | 30            | ns            |
| $t_{TM}$      | $t_{TF} - t_{TR}$ mismatch <sup>5</sup>  |                        |        | 0       | $\pm 2$       | ns            |
| $t_{TS}$      | Transmitter added skew <sup>4,5</sup>  |                        |        | 0       | $\pm 2$       | ns            |
| $t_{TON}$     | Transmitter turn on pulse width (see Figure 8)   | $V_{TX\pm} = 1V$ peak  | 10     |         | 35            | ns            |
| $t_{TOFF}$    | Transmitter turn off pulse width (see Figure 8)  | $V_{TX\pm} = 1V$ peak  | 125    |         | 200           | ns            |
| $t_{CON}$     | Collision turn on delay (see Figure 9)   | 0V to -2V step at RXI  |        |         | 13            | bits          |
| $t_{COFF}$    | Collision turn off delay (see Figure 9)  | -2V to 0V step at RXI  |        |         | 16            | bits          |
| $t_{CHI}$     | Collision high to idle time (see Figure 9)   | Measured to +210mV     | 200    |         | 850           | ns            |
| $f_{CD}$      | Collision frequency (see Figure 9)   |                        | 8.5    | 10      | 11.5          | MHz           |
| $t_{CP}$      | Collision signal pulse width (see Figure 9)  |                        | 35     |         | 70            | ns            |
| $t_{HON}$     | Heartbeat turn on delay (see Figure 10)  |                        | 0.6    |         | 1.6           | $\mu\text{s}$ |
| $t_{HW}$      | Heartbeat test duration (see Figure 10)  |                        | 0.5    |         | 1.5           | $\mu\text{s}$ |
| $t_{JA}$      | Jabber activation delay measured from TX $\pm$ to CD $\pm$ (see Figure 11)                               |                        | 20     |         | 60            | ms            |
| $t_{JR}$      | Jabber reset delay measured from TX $\pm$ to CD $\pm$ (see Figure 11)                                    |                        | 250    |         | 650           | ms            |
| <b>LEDs</b>   |  |                        |        |         |               |               |
| $t_{LED}$     | Turn-on or turn-off delay of LEDs  |                        |        |         | 10            | $\mu\text{s}$ |
| $t_{XLEDON}$  | XLED maximum on time   |                        | 90     | 115     | 135           | ms            |
| $t_{XLEDOFF}$ | XLED minimum off time  |                        | 5      | 7       | 10            | ms            |
| $t_{RLEDON}$  | RLED maximum on time   |                        | 90     | 115     | 135           | ms            |
| $t_{RLEDOFF}$ | RLED minimum off time  |                        | 5      |         | 10            | ms            |
| $t_{CLEDON}$  | CLED minimum on time   |                        | 10     | 14      | 18            | ms            |
| $t_{JLEDON}$  | JLED maximum on time   |                        |        |         |               |               |
| $t_{JLEDOFF}$ | JLED minimum off time  |                        |        |         |               |               |

**NOTES:**

- All typicals are for  $V_{EE} = -9V$  and  $T_A = 27^\circ\text{C}$ .
- Measured on secondary side of isolation transformer (see Figures 3 and 4, Connection Diagram). The transformer has a 1:1 turn ratio with an inductance between 30 and  $100\mu\text{H}$  at 5MHz.
- The rise and fall times are measured as the time required for the differential voltage to change from  $-225\text{mV}$  to  $+225\text{mV}$ , or  $+225\text{mV}$  to  $-225\text{mV}$ , respectively.
- Difference in propagation delay between rising and falling edges at TXO.
- Not 100% tested in production.

# Enhanced coaxial Ethernet transceiver

# NE83Q93

## FUNCTIONAL DESCRIPTION

The NE83Q93 is a low power BiCMOS coaxial Ethernet transceiver which complies with the IEEE 802.3 specification and offers a number of additional features. These features are:

1. Low current consumption of typically 15mA when idle and 80mA while transmitting without collision allows smaller DC-DC converter to be used for the isolated power supply (no external pull-down resistors).
2. Automatic selection between AUI cable and coaxial connections by placing the AUI outputs in a high impedance state when the coaxial cable is disconnected. This eliminates the need for changing a jumper position on the Ethernet board when selecting either Thin Ethernet or remote transceiver connections.
3. High efficiency AUI drivers for the RX $\pm$  and CD $\pm$  ports automatically power down when idling and are powered-up when a receive signal is detected. This is very important/useful for power sensitive applications such as lap-top computers or PCMCIA cards.
4. The NE83Q93 advanced AUI driver (RX $\pm$  and CD $\pm$ ) design requires no external pull-down resistors (500 $\Omega$ ) to drive a terminated (78 $\Omega$ ) AUI cable and still meets the IEEE 802.3 specification. The drivers will also operate correctly if external resistors are present, so that they can be retro-fitted into existing 8392 designs. However, an extra current of 7mA/output (for 500 $\Omega$  resistors) would be generated, by these resistors, regardless of whether the transceiver is idle or responding to traffic.
5. Transmit enable input and carrier sense output for direct use in repeater applications.
6. LED control circuitry and drivers for indicating the transmit, receive, collision, jabber and link status of the transceiver unit.

## Receiver Functions

The receiver consists of an input buffer, a cable equalizer, a 4-pole Bessel low pass filter, a squelch circuit and a differential line driver.

The buffer provides high input resistance and low input capacitance to minimize loading and reflections on the coaxial cable.

The equalizer is a high pass filter that compensates for the low pass effect of the coaxial cable and results in a flatband response over all signal frequencies to minimize signal distortion.

The 4-pole Bessel low pass filter extracts the average DC voltage level on the coaxial cable for use by the receiver squelch and collision detection circuits.

The receiver squelch circuit prevents noise on the coaxial cable from falsely triggering the receiver in the absence of a true signal. At the beginning of a packet, the receiver turns on when the DC level from the low pass filter exceeds the DC squelch threshold and the received packet has started with a 01 bit sequence with acceptable timing parameters. For normal signal levels this will take less than 500ns, or 5 bits. However, at the end of a packet, a fast receiver turn off is needed to reject both dribble bits on the coaxial cable and spurious responses due to settling of the on-chip bandpass filter. This is accomplished by an AC timing circuit that disables the receiver if the signal level on the coaxial cable remains high for typically 250ns and only enables the receiver again after approximately .5 $\mu$ s. Figures 6 and 7 illustrate receiver timing.

The differential line driver provides typically  $\pm$ 900mV signals to the DTE with less than 7ns rise and fall times. When in idle state (no received signal) its outputs provide <20mV differential voltage offset to minimize DC standing current in the isolation transformer.

## Transmitter Functions

The transmitter has differential inputs and an open collector current driver output. The differential input common mode voltage is established by the CTI and should not be altered by external circuitry. Controlled rise and fall times of 25ns ( $\pm$ 5ns) minimize higher harmonic components in the transmitted spectrum, while matching of these rise and fall times to typically 2ns minimizes signal jitter. The drive current levels of the CTI are set by an on-chip bandgap voltage reference and an external 1% resistor. An on-chip isolation diode is provided to reduce the transmitter's coaxial cable load capacitance. For Thin Ethernet applications, no further external isolation diode is required, since the NE83Q93 meets the capacitive loading specifications. For Ethernet applications a further external diode should be added to reduce loading capacitance.

The transmitter squelch circuit ensures that the transmitter can only be enabled if the transmitted packet begins with a 01 bit sequence where the negative-going differential signals are typically greater than 225mV in magnitude and 25ns in duration.

The transmitter will be disabled at the end of a packet if there are no negative going signals of greater than 225mV for more than typically 150ns. Figure 8 illustrates transmitter timing.

## Collision Functions

The collision detection scheme implemented in the NE83Q93 is receive mode detection, which detects a collision between any two stations on the network with certainty at all times, irrespective of whether or not the local DTE is producing one of the colliding signals. This is the only detection scheme allowed by the IEEE 802.3 standard for both repeater and non-repeater nodes.

The collision circuitry consists of the 4-pole Bessel low pass filter, a comparator, a precision voltage reference that sets up the collision threshold, a heartbeat generator, a 10MHz oscillator, and a differential line driver.

The collision comparator monitors the DC level at the output of the low pass filter and enables the line driver if it is more negative than the collision threshold. A collision condition is indicated to the DTE by a 10MHz oscillation signal at the CD outputs and typically occurs within 700ns of the onset of the collision. The collision signal begins with a negative-going pulse and ends with a continuous high-to-idle state longer than 170ns. Figure 9 illustrates collision timing.

At the end of every transmission, the heartbeat generator creates a pseudo collision to ensure that the collision circuitry is properly functioning. This pseudo collision consists of a 1 $\mu$ s burst of 10MHz oscillation at the line driver outputs approximately 1 $\mu$ s after the end of the transmission. The heartbeat function can be disabled externally by connecting the HBE (heartbeat enable) to V<sub>EE</sub>. This allows the CTI to be used in repeater applications. Figure 10 illustrates heartbeat timing.

## Jabber Functions

The jabber timer monitors the transmitter and inhibits transmission if it is active for longer than typically 30ms. The jabber circuit then enables the collision outputs for the remainder of the data packet and for typically 450ns (unjab time) after it has ended. At this point the transmitter becomes uninhibited. Figure 11 illustrates jabber timing.



# Enhanced coaxial Ethernet transceiver

# NE83Q93

## Control Interface Signals

The NE83Q93 provides two input and one output signal for mode control and interfacing within repeaters. The output signal is Carrier Sense (CRS) and the input signals are Heartbeat Enable (HBE) and Transmit Enable (TEN).

The HBE input controls the transmission of the heartbeat (or SQE) signal to the DTE for testing the collision detection function. It is normally hardwired to  $V_{EE}$  or GND.

1. The heartbeat (SQE) function is DISABLED when HBE is connected to  $V_{EE}$
2. The heartbeat (SQE) function is ENABLED when HBE is connected to GND or left floating

The TEN input controls the coaxial transmitter. It is a CMOS compatible input requiring a driving signal with a voltage range of  $V_{EE}$  to  $V_{EE} + 5V$ . It is normally driven through an opto-coupler to provide electrical isolation. A typical application circuit is shown in Figure 4.

1. The coaxial transmitter is DISABLED when a LOW is applied to TEN or it is directly connected to  $V_{EE}$ . Since the loopback function of the NE83Q93 occurs through the coaxial connection the loopback function is also disabled.
2. The coaxial transmitter is ENABLED when a HIGH is applied to TEN or it is directly connected to GND or left floating.

The CRS output indicates the presence of a carrier signal on the coaxial cable. It is open drain output designed to drive the LED of an opto-coupler connected between CRS and LCOM through a current limiting series resistor. A LOW at CRS is  $V_{EE}$  and a HIGH is the voltage at LCOM ( $V_{EE} + 5V$ ).

1. CRS is HIGH (no current) when no carrier is present
2. CRS is LOW (current sinking) when carrier is present

On applying a HIGH to TEN through an opto-coupler the transmitter is enabled but it still has to recognize the normal squelch-qualified 01 bit sequence with the negative-going differential signals meeting the necessary magnitude and duration requirements. The set-up time needed from application of a HIGH at TEN to recognizing the first 01 bit sequence is typically 25ns. The propagation delay through an opto-coupler is of the order of 200ns.

## AUI Selection/Under Voltage Lockout

The transmit and receive squelch circuits of the NE83Q93 remain active if the absolute value of  $V_{EE}$  is less than the threshold for under voltage lockout,  $V_{UVL}$ . This prevents glitches from appearing on either the AUI or coaxial cable during power up and power down.

There is no collision announcement during power up and the transceiver waits for 400ms before becoming enabled.

If RXI is disconnected from the coaxial cable after power up, its voltage will fall towards  $V_{EE}$ . If the absolute value of this voltage exceeds the AUI disable voltage,  $V_{DIS}$ , for longer than 800ms, the transmit and receive squelch circuits remain active and, in addition, the AUI drivers become high impedance. This permits AUI connections to be hard wired together, e.g., the coaxial transceiver and a 10BASE-T transceiver, with the signal path determined by which transceiver is connected to its external cable.

There is a 400ms collision announcement on disconnecting RXI, but there is no announcement on re-connection. This feature can be disabled by pulling RXI up with a 200k $\Omega$  to ground.

## Detection of Coaxial Cable Faults

In the NE83Q93 there is no internal loopback path from the TX inputs to the RX outputs. This means that, when the local DTE is transmitting, the signal will only be present at the receiver outputs RX+ and RX- if it appears on the coaxial cable and is larger than the receiver squelch threshold  $V_{RS}$ . If a short circuit fault condition occurs at the cable connector to the CTI, then no signal will appear at the receiver outputs.

In the case of an open circuit at the coaxial cable connector there will also be no signal at the receiver outputs due to the AUI disabling mode of the NE83Q93. However, a heartbeat signal will be present following a transmission attempt for the short circuit condition, but not for the open circuit.

A coaxial cable with only a single 50 $\Omega$  termination will generate a collision not only at every transmission attempt, but also for every reception attempt due to the receive mode collision detection of the NE83Q93.

## Status Indicator Functions

The NE83Q93 provides five status outputs, the open drain device connected to each is capable of directly driving an LED or opto-coupler, or other logic circuits if an external pull-up resistor is used. The functional descriptions below are for an LED connected between the output and LCOM ( $V_{EE} + 5V$ ) through a current limiting series resistor.

The LINK signal indicates the status of the coaxial connection.

- The LED is ON when the transceiver is connected to a properly terminated coaxial cable.
- The LED is OFF when the coaxial cable is disconnected from the transceiver, or if the coaxial connection is unterminated.

The XLED signal indicates the status of the transmitter.

- The LED is OFF when there is no transmission in progress
- The LED is turned ON when data is being transmitted and remains ON for typically 115ms.

The RLED signal indicates the status of the receiver.

- The LED is OFF when no signal is being received.
- The LED is turned ON when data is received and remains ON for typically 115ms.

The CLED signal indicates the status of the collision detection circuit.

- The LED is OFF for no collision.
- The LED turns ON when a collision is detected and remains ON for typically 12ms after the end of the collision.
- In the event of another collision during the latter 6ms of the 12 ms delay period after the end of the last collision, the LED will turn off for typically 6ms then back ON to indicate the new collision.

The JLED signal indicates the status of the jabber control circuit.

- The LED is OFF for a no-jab condition.
- The LED turns ON when the coaxial transmitter output is jabbed.
- The LED turns back off when the transmitter is unjabbed.



# Enhanced coaxial Ethernet transceiver

# NE83Q93

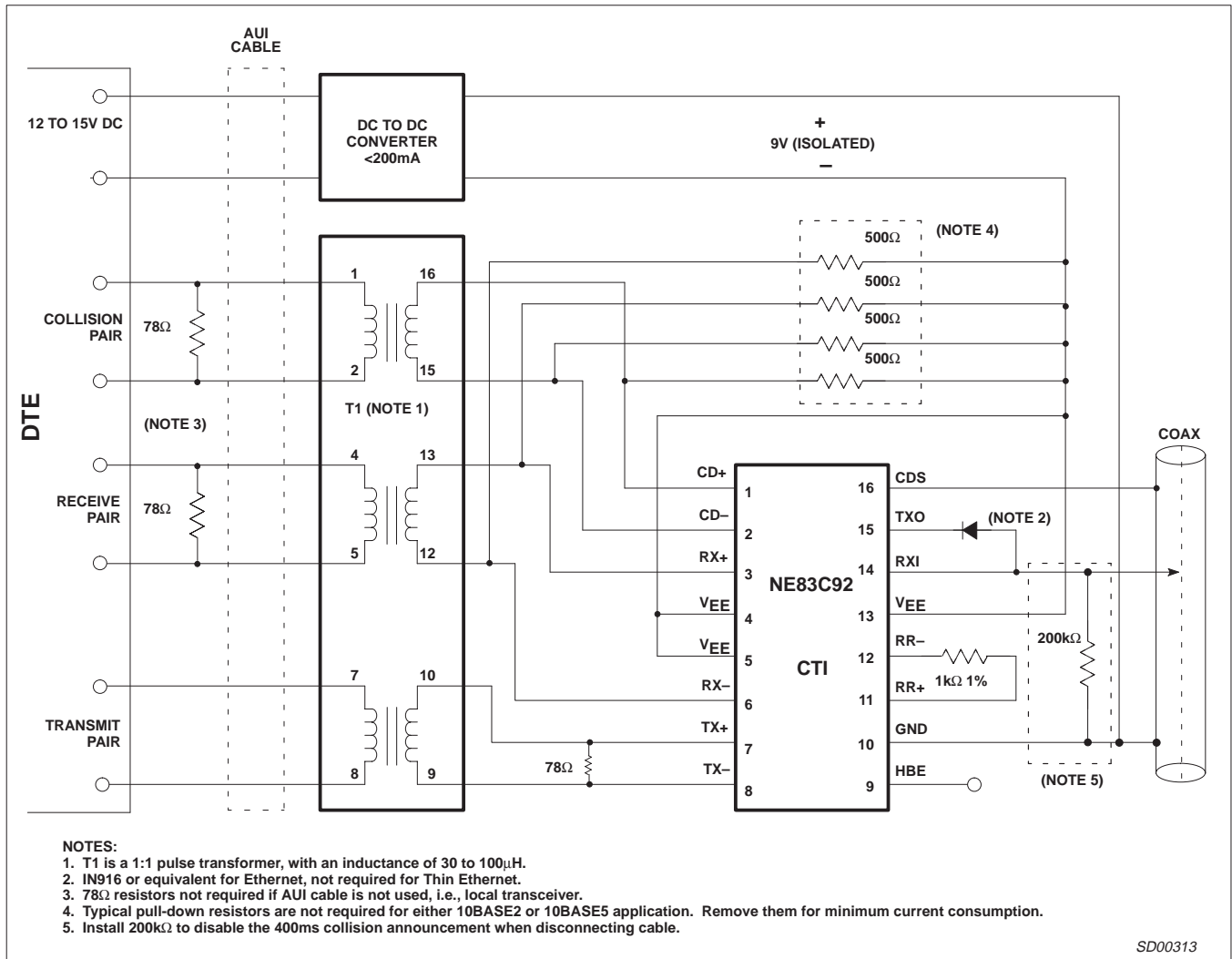

SD00313

Figure 3. Connection Diagram for Standard 8392 Applications

# Enhanced coaxial Ethernet transceiver

# NE83Q93

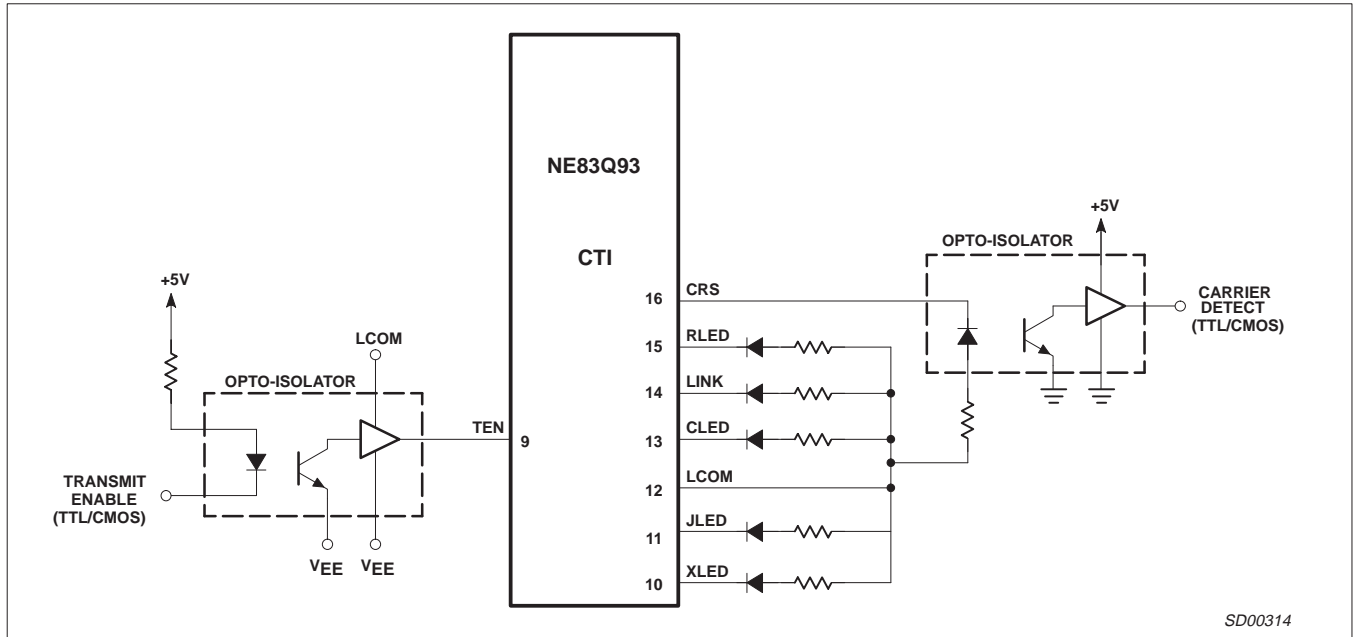

Figure 4. Control Interface Connections

SD00314

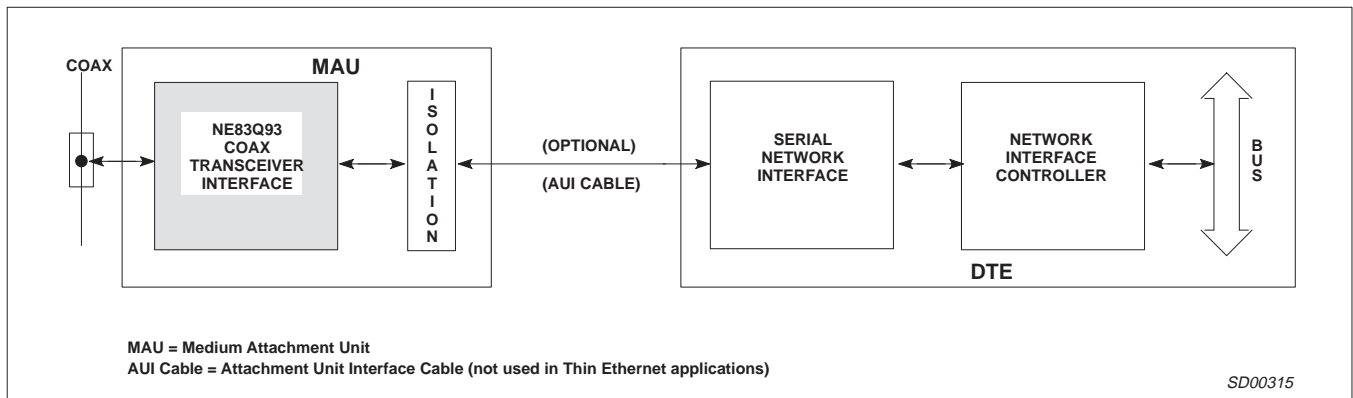

Figure 5. Interface Diagram for Ethernet/Thin Ethernet Local Area Network

SD00315

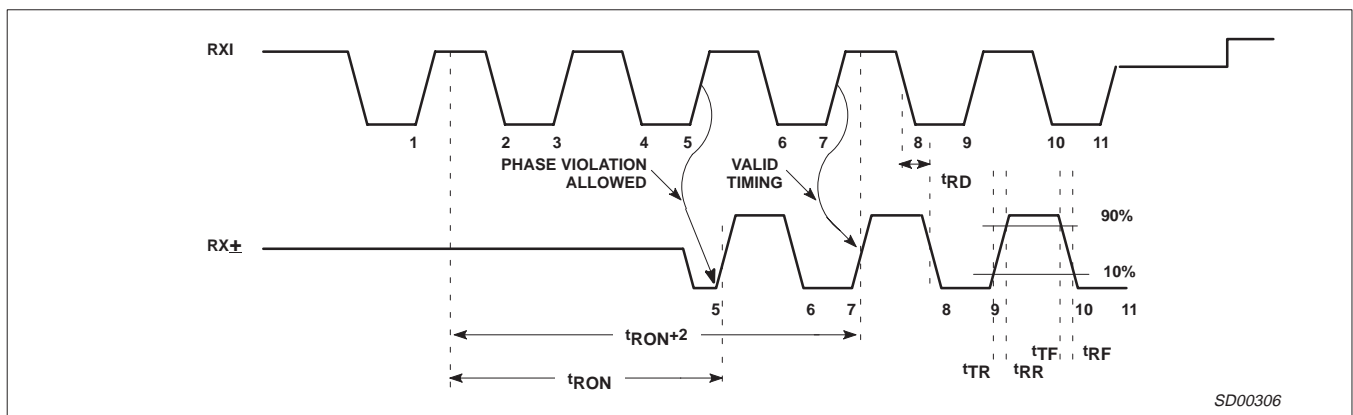

Figure 6. Receiver Timing

SD00306

Enhanced coaxial Ethernet transceiver

NE83Q93

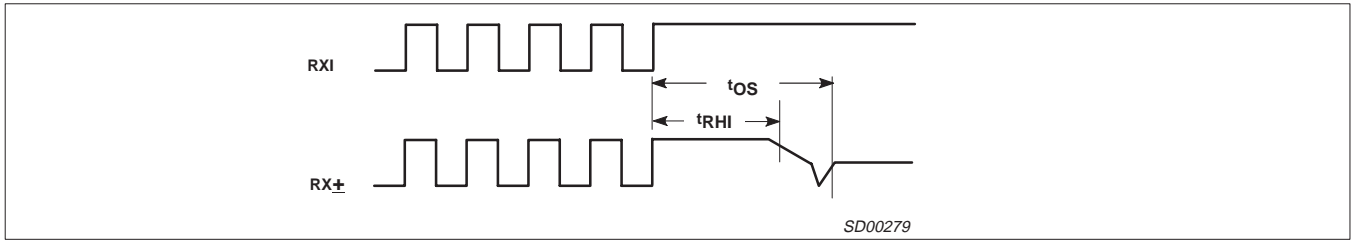

Figure 7. Receiver End-of-Packet Timing

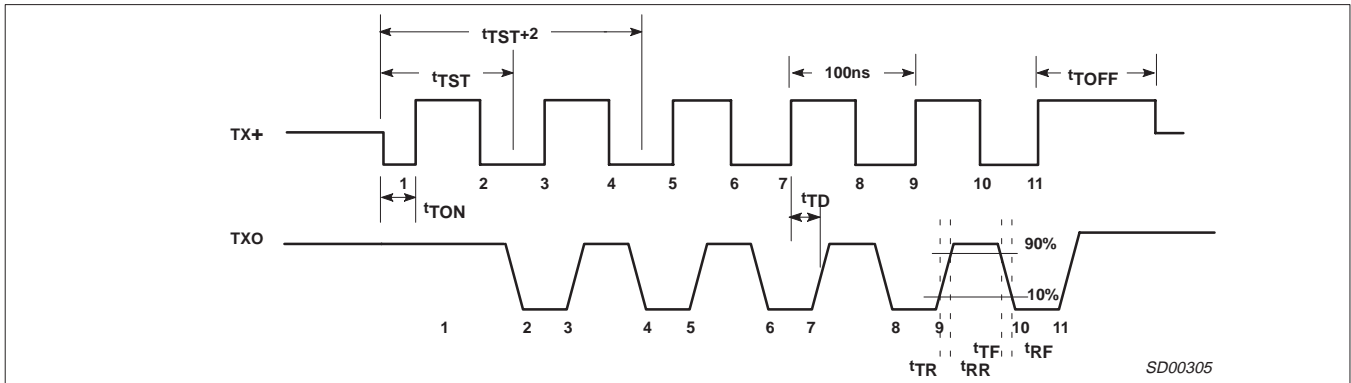

Figure 8. Transmitter Timing

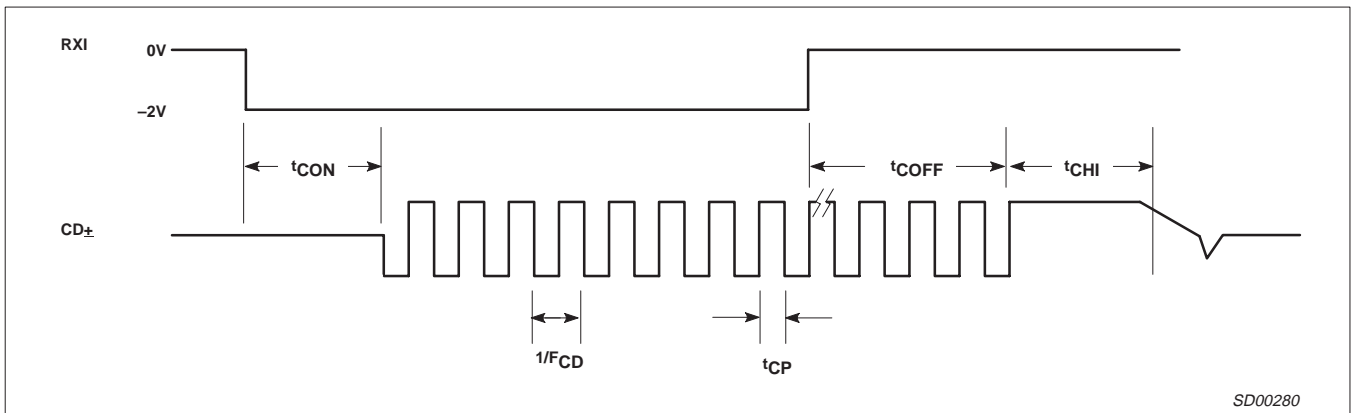

Figure 9. Collision Timing

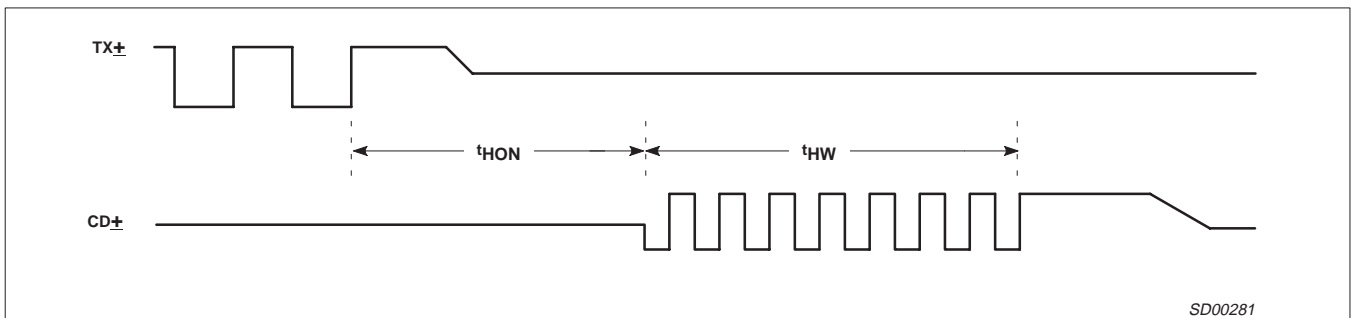
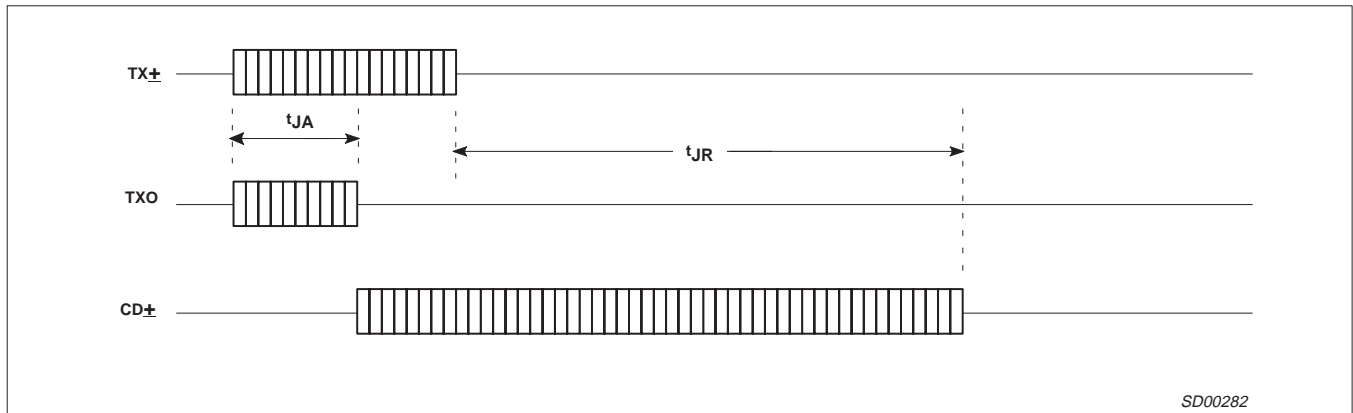

Figure 10. Heartbeat Timing

# Enhanced coaxial Ethernet transceiver

NE83Q93



SD00282

Figure 11. Jabber Timing

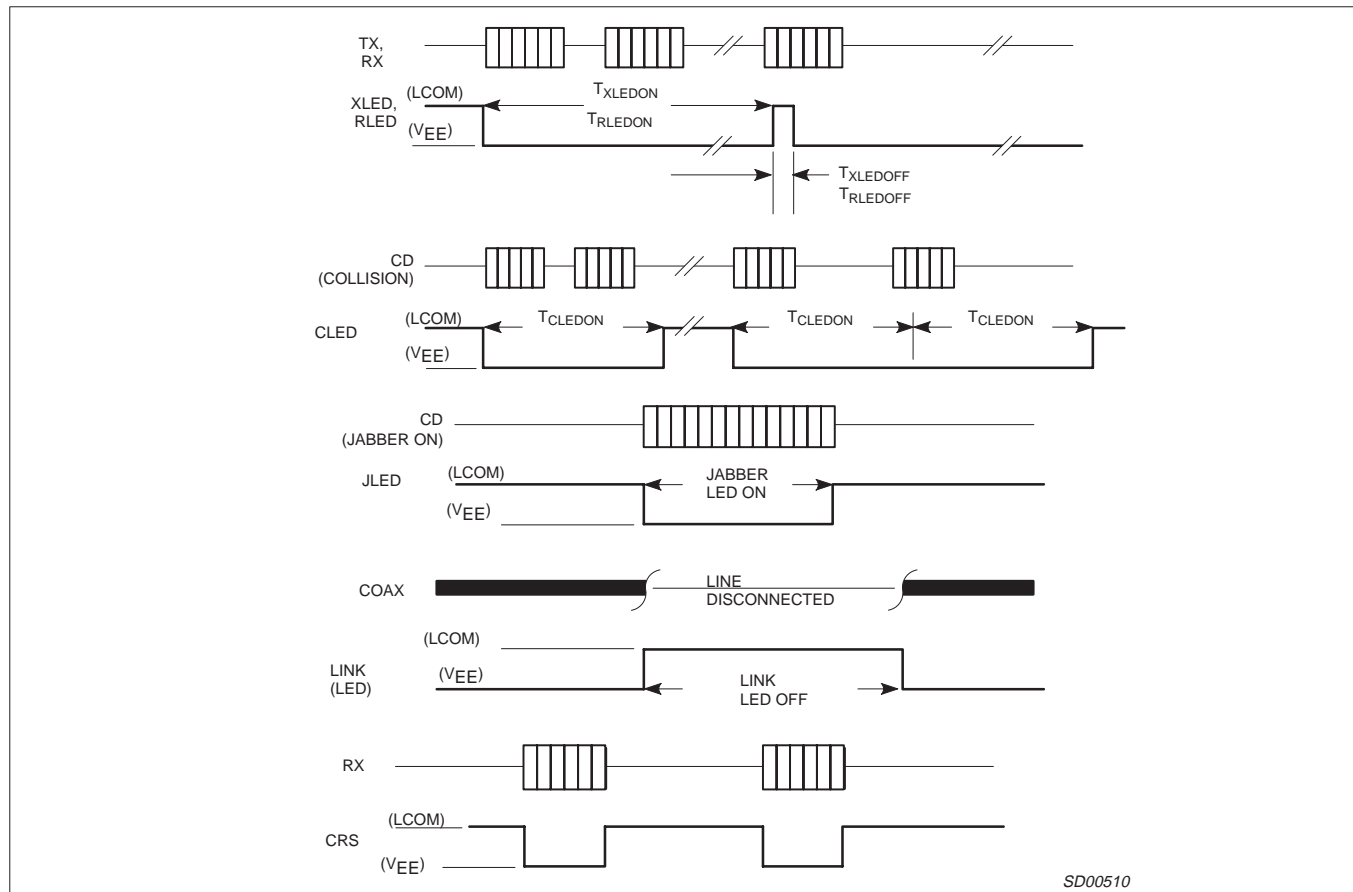

SD00510

Figure 12. LED Timing

# Enhanced coaxial Ethernet transceiver

# NE83Q93

DIP24: plastic dual in-line package; 24 leads (300 mil)

SOT222-1

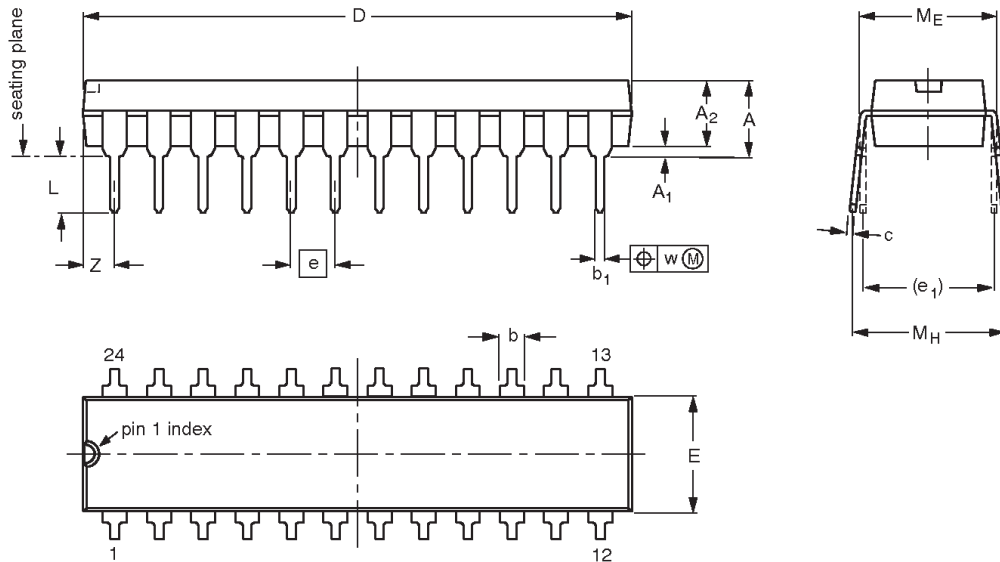

**DIMENSIONS (millimetre dimensions are derived from the original inch dimensions)**

| UNIT   | A max. | A <sub>1</sub> min. | A <sub>2</sub> max. | b              | b <sub>1</sub> | c              | D <sup>(1)</sup> | E <sup>(1)</sup> | e     | e <sub>1</sub> | L              | M <sub>E</sub> | M <sub>H</sub> | w    | Z <sup>(1)</sup> max. |
|--------|--------|---------------------|---------------------|----------------|----------------|----------------|------------------|------------------|-------|----------------|----------------|----------------|----------------|------|-----------------------|
| mm     | 4.70   | 0.38                | 3.94                | 1.63<br>1.14   | 0.56<br>0.43   | 0.36<br>0.25   | 31.9<br>31.5     | 6.73<br>6.48     | 2.54  | 7.62           | 3.51<br>3.05   | 8.13<br>7.62   | 10.03<br>7.62  | 0.25 | 2.05                  |
| inches | 0.185  | 0.015               | 0.155               | 0.064<br>0.045 | 0.022<br>0.017 | 0.014<br>0.010 | 1.256<br>1.240   | 0.265<br>0.255   | 0.100 | 0.300          | 0.138<br>0.120 | 0.32<br>0.30   | 0.395<br>0.300 | 0.01 | 0.081                 |

**Note**

1. Plastic or metal protrusions of 0.01 inches maximum per side are not included.

| OUTLINE VERSION | REFERENCES |          |      |  | EUROPEAN PROJECTION | ISSUE DATE |
|-----------------|------------|----------|------|--|---------------------|------------|
|                 | IEC        | JEDEC    | EIAJ |  |                     |            |
| SOT222-1        |            | MS-001AF |      |  |                     | 95-03-11   |

# Enhanced coaxial Ethernet transceiver

# NE83Q93

**SO24:** plastic small outline package; 24 leads; body width 7.5 mm

**SOT137-1**

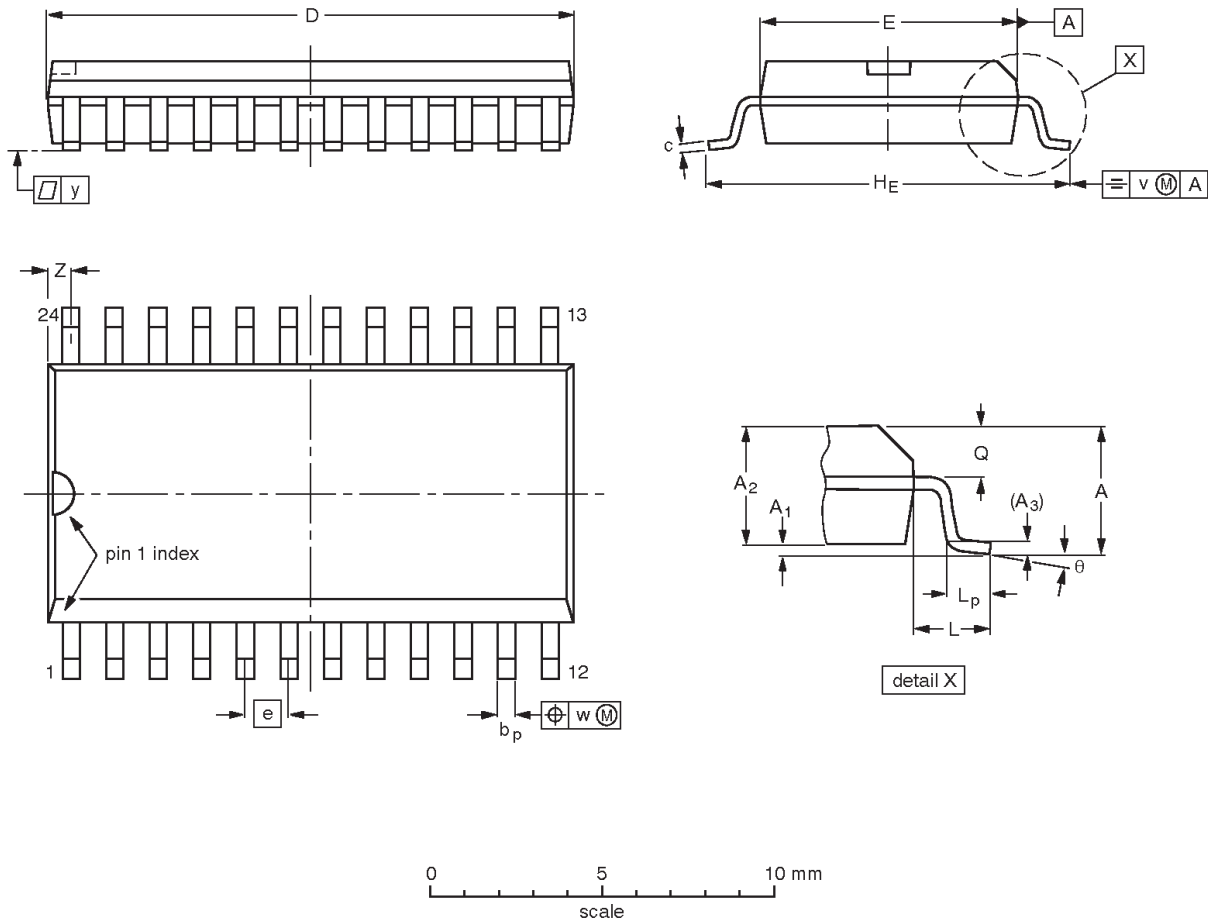

**DIMENSIONS (inch dimensions are derived from the original mm dimensions)**

| UNIT   | A max. | A <sub>1</sub> | A <sub>2</sub> | A <sub>3</sub> | b <sub>p</sub> | c              | D <sup>(1)</sup> | E <sup>(1)</sup> | e     | H <sub>E</sub> | L     | L <sub>p</sub> | Q              | v    | w    | y     | z <sup>(1)</sup> | θ        |
|--------|--------|----------------|----------------|----------------|----------------|----------------|------------------|------------------|-------|----------------|-------|----------------|----------------|------|------|-------|------------------|----------|
| mm     | 2.65   | 0.30<br>0.10   | 2.45<br>2.25   | 0.25           | 0.49<br>0.36   | 0.32<br>0.23   | 15.6<br>15.2     | 7.6<br>7.4       | 1.27  | 10.65<br>10.00 | 1.4   | 1.1<br>0.4     | 1.1<br>1.0     | 0.25 | 0.25 | 0.1   | 0.9<br>0.4       | 8°<br>0° |
| inches | 0.10   | 0.012<br>0.004 | 0.096<br>0.089 | 0.01           | 0.019<br>0.014 | 0.013<br>0.009 | 0.61<br>0.60     | 0.30<br>0.29     | 0.050 | 0.419<br>0.394 | 0.055 | 0.043<br>0.016 | 0.043<br>0.039 | 0.01 | 0.01 | 0.004 | 0.035<br>0.016   |          |

**Note**

1. Plastic or metal protrusions of 0.15 mm maximum per side are not included.

| OUTLINE VERSION | REFERENCES |          |      |  | EUROPEAN PROJECTION | ISSUE DATE           |
|-----------------|------------|----------|------|--|---------------------|----------------------|
|                 | IEC        | JEDEC    | EIAJ |  |                     |                      |
| SOT137-1        | 075E05     | MS-013AD |      |  |                     | 95-01-24<br>97-05-22 |

---

Enhanced coaxial Ethernet transceiver

NE83Q93

---

**NOTES**



## Enhanced coaxial Ethernet transceiver

NE83Q93

## Data sheet status

| Data sheet status         | Product status | Definition [1]   |
|---------------------------|----------------|--|
| Objective specification   | Development    | This data sheet contains the design target or goal specifications for product development. Specification may change in any manner without notice.  |
| Preliminary specification | Qualification  | This data sheet contains preliminary data, and supplementary data will be published at a later date. Philips Semiconductors reserves the right to make changes at any time without notice in order to improve design and supply the best possible product. |
| Product specification     | Production     | This data sheet contains final specifications. Philips Semiconductors reserves the right to make changes at any time without notice in order to improve design and supply the best possible product.   |

[1] Please consult the most recently issued datasheet before initiating or completing a design.

## Definitions

**Short-form specification** — The data in a short-form specification is extracted from a full data sheet with the same type number and title. For detailed information see the relevant data sheet or data handbook.

**Limiting values definition** — Limiting values given are in accordance with the Absolute Maximum Rating System (IEC 134). Stress above one or more of the limiting values may cause permanent damage to the device. These are stress ratings only and operation of the device at these or at any other conditions above those given in the Characteristics sections of the specification is not implied. Exposure to limiting values for extended periods may affect device reliability.

**Application information** — Applications that are described herein for any of these products are for illustrative purposes only. Philips Semiconductors make no representation or warranty that such applications will be suitable for the specified use without further testing or modification.

## Disclaimers

**Life support** — These products are not designed for use in life support appliances, devices or systems where malfunction of these products can reasonably be expected to result in personal injury. Philips Semiconductors customers using or selling these products for use in such applications do so at their own risk and agree to fully indemnify Philips Semiconductors for any damages resulting from such application.

**Right to make changes** — Philips Semiconductors reserves the right to make changes, without notice, in the products, including circuits, standard cells, and/or software, described or contained herein in order to improve design and/or performance. Philips Semiconductors assumes no responsibility or liability for the use of any of these products, conveys no license or title under any patent, copyright, or mask work right to these products, and makes no representations or warranties that these products are free from patent, copyright, or mask work right infringement, unless otherwise specified.

Philips Semiconductors  
811 East Arques Avenue  
P.O. Box 3409  
Sunnyvale, California 94088-3409  
Telephone 800-234-7381

© Copyright Philips Electronics North America Corporation 1998  
All rights reserved. Printed in U.S.A.

print code

Date of release: 08-98

Document order number:

*Let's make things better.*